

LS2 Leg Set

Instruction & Maintenance Manual

LS2 支腿安装使用维护手册



Suzhou LinkedGo Transfer System Co.,Ltd.

苏州领科工业技术有限公司

Structure Diagram 结构示意图

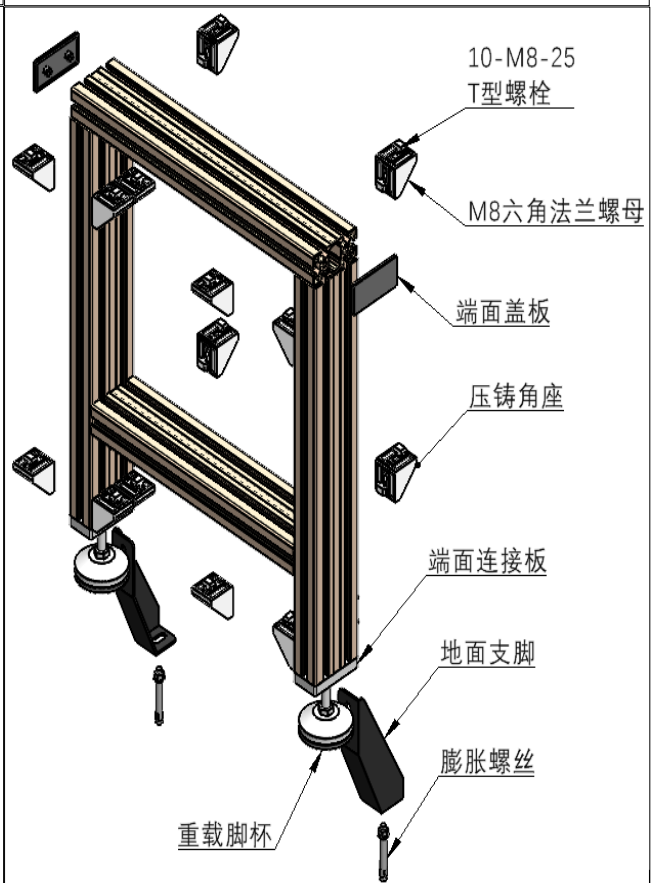
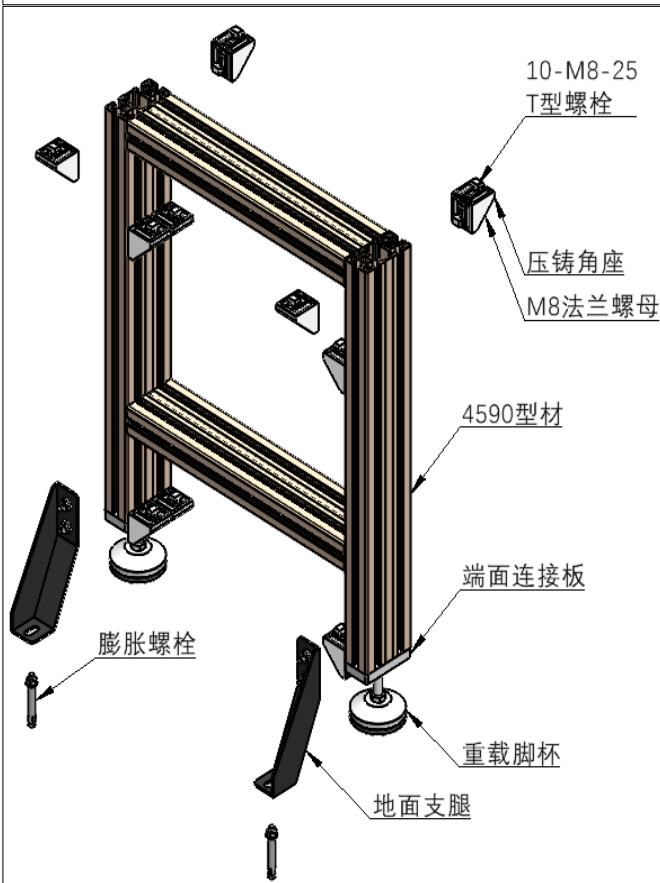
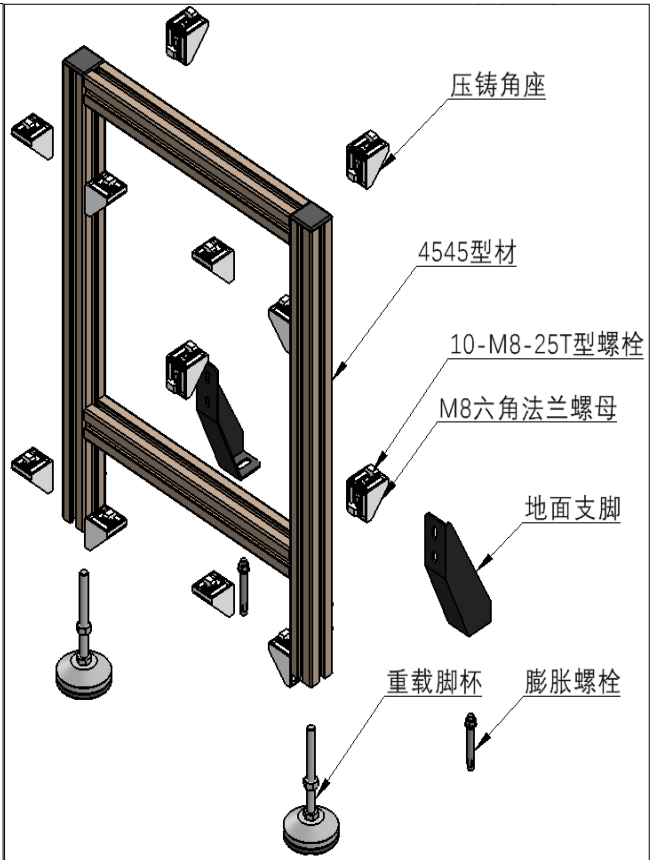
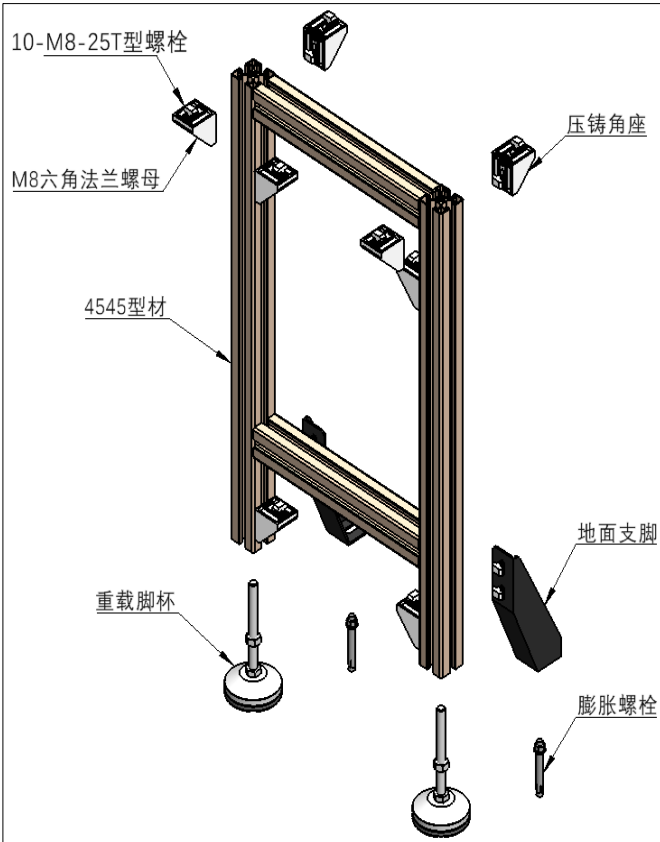

产品特征

安装步骤

维护保养

- 1、 Legs are used to support a conveying section.
- 1、 支腿用以支撑一个输送段。
- 2、 Material: Aluminum profile, anodized.
- 2、 材质：铝型材，阳极氧化。
- 3、 Conveying width (track width in the conveying direction):
- LS2: 160-1200
- LS2-H: 160-1200
- 3、 输送宽度（输送方向的轨道宽度）:
- LS2: 160-1200
- LS2-H: 160-1200
- 4、 Conveying height: 375-2000
- 4、 输送高度：375-2000

产品特征

Model Description 型号说明

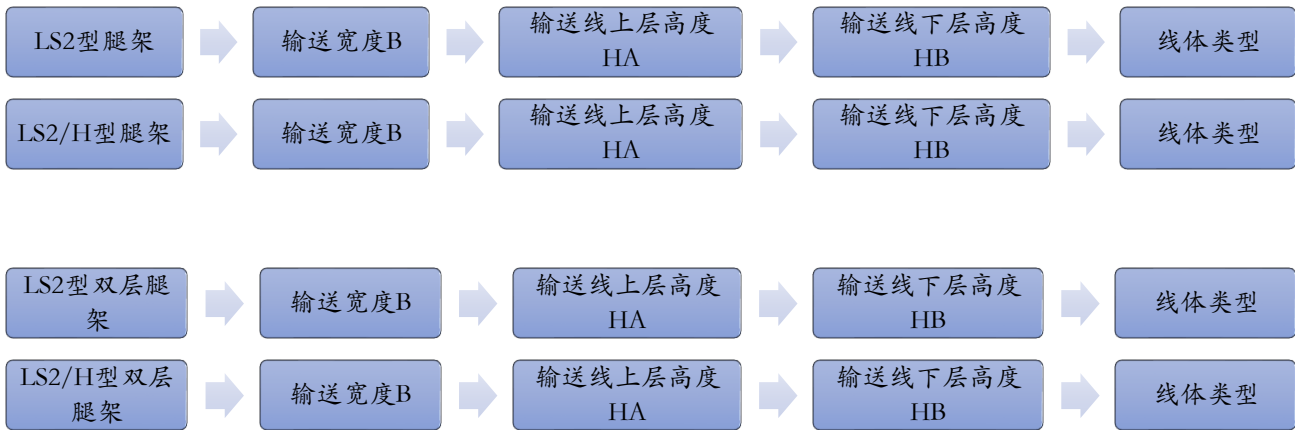

安装步骤

例: LS2-B160-HA1000-HB500-T1-TBC2

维护保养

安装步骤 Installation steps

A Install the LS2 support leg as shown in the following figure.

A 按下图所示，安装LS2支腿。

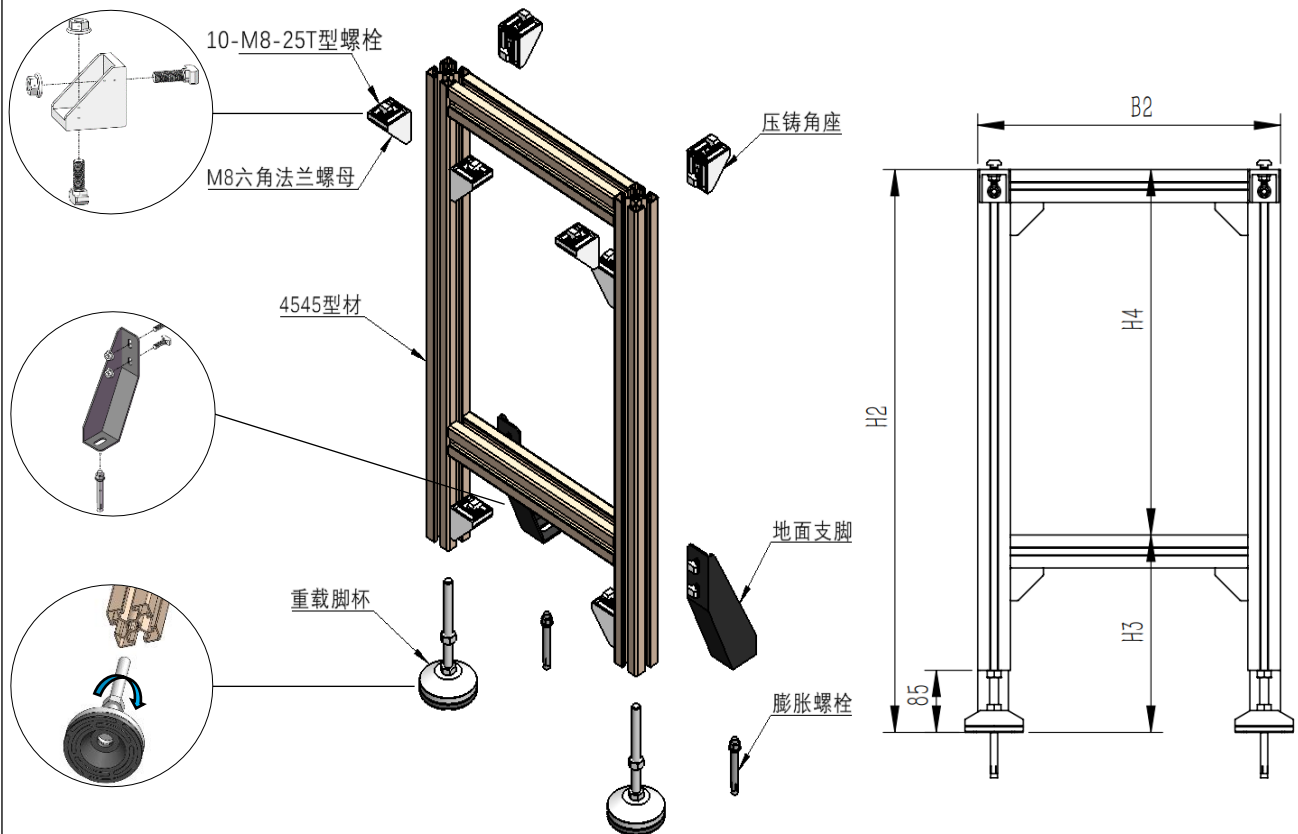

B Tap the bottom of the two leg profiles with M12x75 teeth.

B 将两根支腿型材底部攻 M12x75 的牙。

C Lock and fix the 4545 profile frame with die cast corner seats.

C 4545 型材框架用压铸角座锁紧固定。

D Screw the foot cup to the bottom of the profile, rotate the M12 hex nut until it is horizontally pressed against the bottom of the profile.

D 将脚杯拧到型材底部，旋转 M12 六角螺母，直到水平紧贴型材底面为止。

E Lock the ground support feet vertically onto the 45 profile and install the expansion bolts of the ground support feet.

E 将地面支脚垂直锁至 45 型材上，安装地面支脚的膨胀螺栓。

F Install two pairs of die cast corner seats at the top of the leg profile to lock the conveyor line placed above the leg.

F 在支腿型材顶部安装两对压铸角座，用于锁紧放置在支腿上方的输送线。

G Install the LS2 double-layer legs frame as shown in the following diagram.

G 按下图所示，安装LS2型双层腿架。

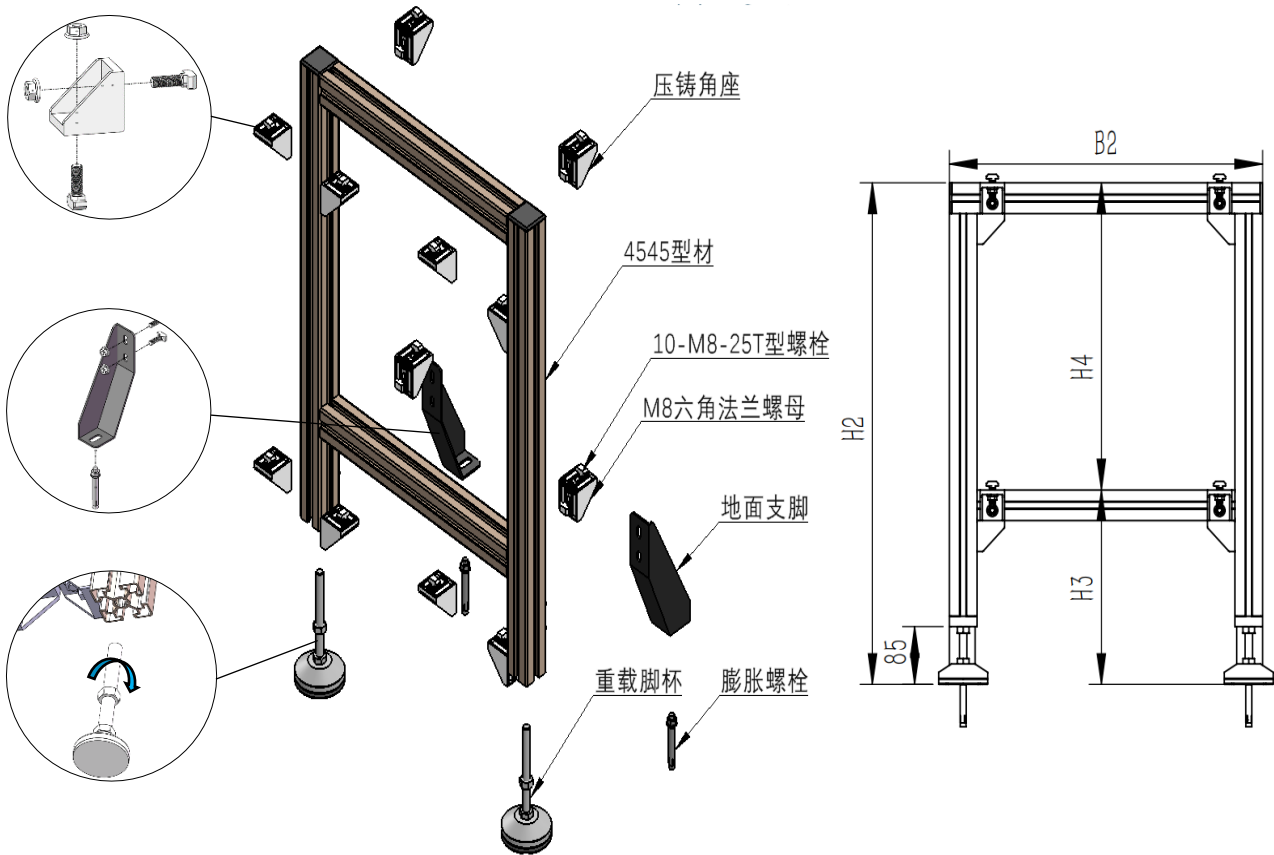

H Tapping M12x75 teeth at the bottom of the leg profile.

H 在支腿型材底部攻 M12x75 的牙。

I Lock and fix the 4545 profile frame with die cast corner seats.

I 4545 型材框架用压铸角座锁紧固定。

J Screw the foot cup to the bottom of the profile, rotate the M12 hex nut until it is horizontally pressed against the bottom of the profile.

J 将脚杯拧到型材底部，旋转 M12 六角螺母，直到水平紧贴型材底面为止。

K Lock the ground support feet vertically onto the 45 profile and install the expansion bolts of the ground support feet.

K 将地面支脚垂直锁至 45 型材上，安装地面支脚的膨胀螺栓。

L Install two pairs of die cast corner seats on both sides of the two cross brace profiles to lock the conveyor line placed above the upper and lower cross braces.

L 在两根横撑型材两侧分别安装两对压铸角座，用于锁紧放置在上下横撑上方的输送线。

M Install the LS2/H legs as shown in the following figure.

M 按下图所示，安装 LS2/H 支腿。

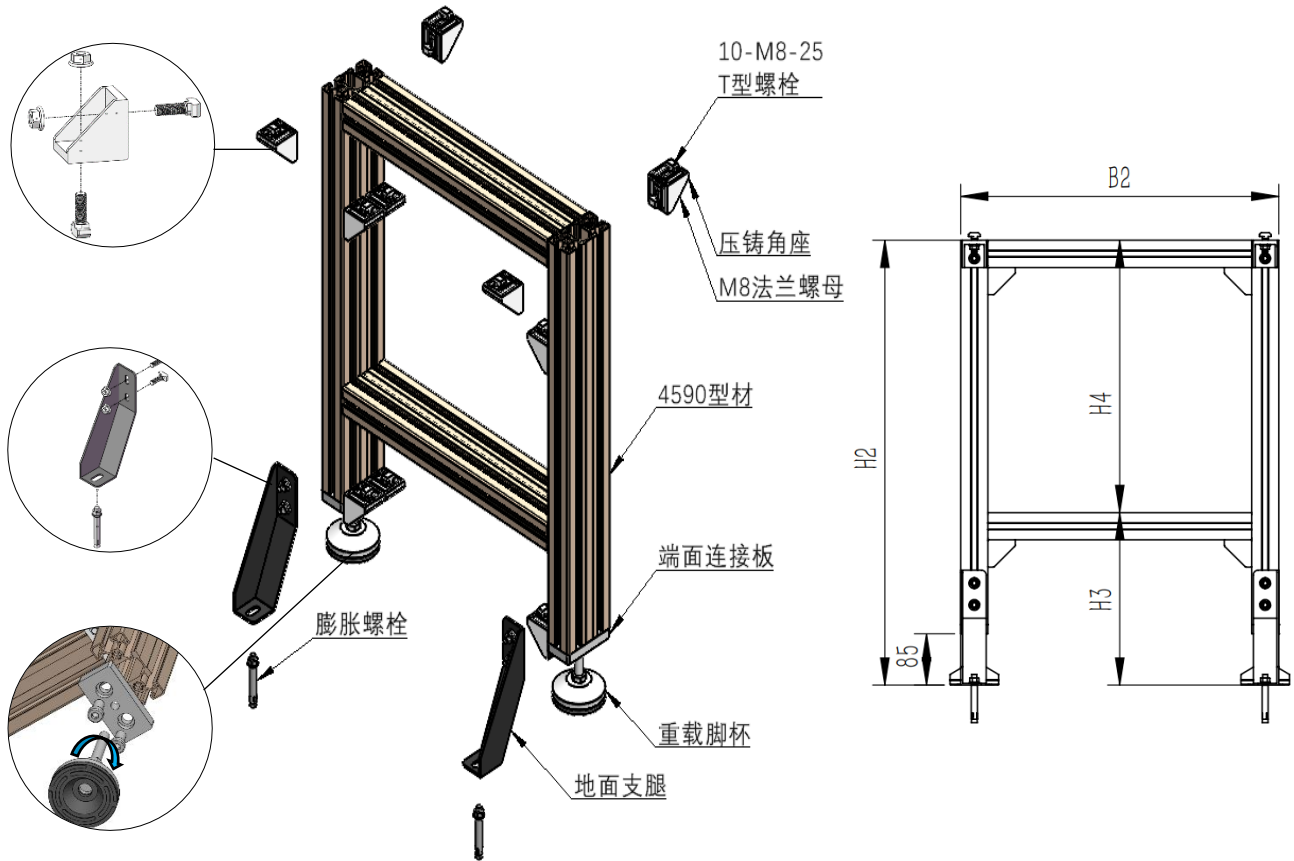

M Tapping M12x25 teeth at the bottom of the leg profile.

M 在支腿型材底部攻 M12x25 的牙。

N Fix the two bottom cross braces to the leg profile using 4545 angle seats.

N 用 4545 角座将两个底部横撑固定到支腿型材上。

O Fix the end face connecting plate to the bottom surface of the profile.

O 将端面连接板固定到型材底面。

P Install the foot cup.

P 安装脚杯。

Q Install the 4545 die cast corner seat onto the top of the support leg profile.

Q 将 4545 压铸角座安装到支腿型材顶部。

R Install the LS2/H-type double-layer leg frame as shown in the following diagram.

R 按下图所示，安装LS2/H型双层腿架。

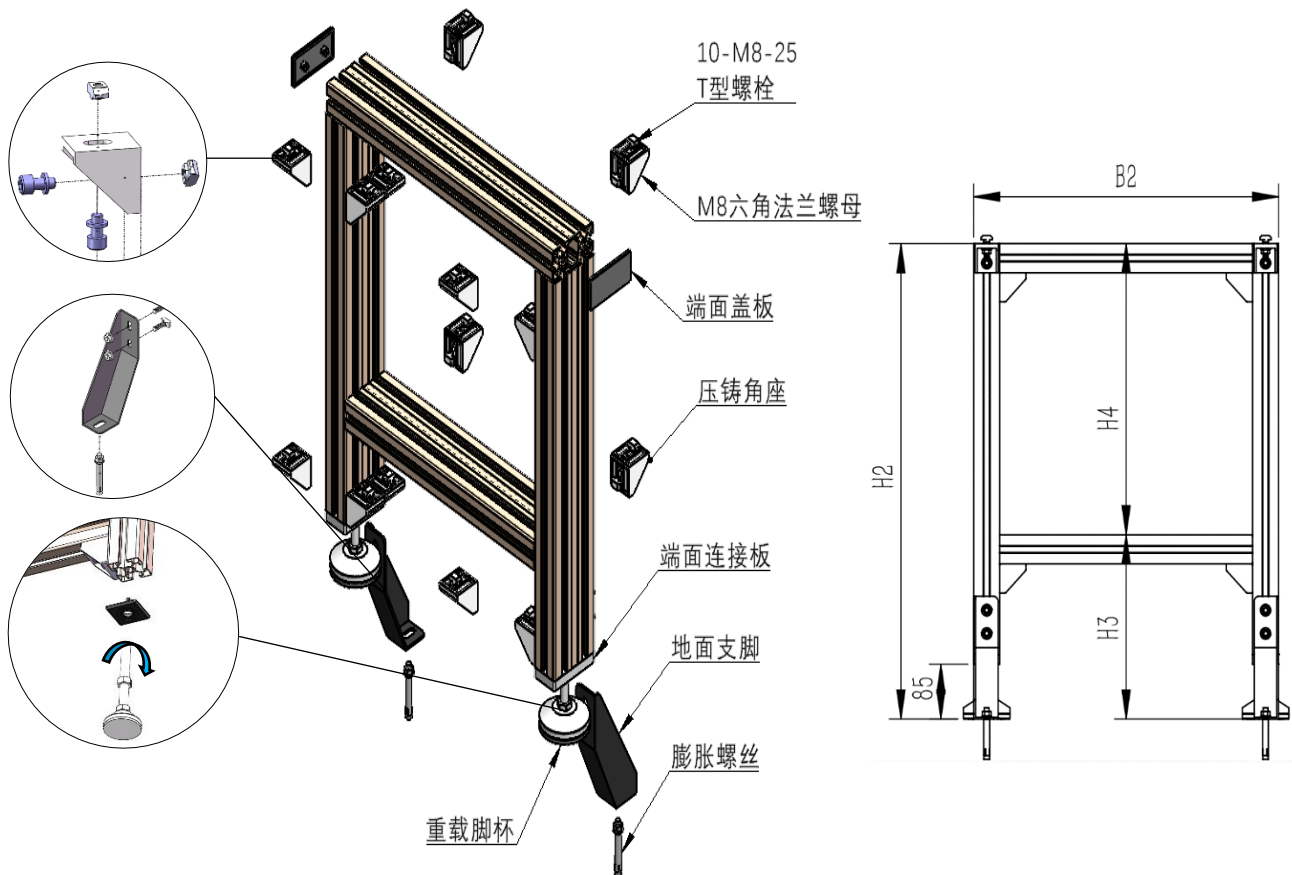

R Tapping M12x25 teeth at the bottom of the leg profile.

R 在支腿型材底部攻 M12x25 的牙。

S Fix the two bottom cross braces to the leg profile using 4545 angle seats.

S 用 4545 角座将两个底部横撑固定到支腿型材上。

T Fix the end face connecting plate to the bottom surface of the profile.

T 将端面连接板固定到型材底面。

U Install the foot cup.

U 安装脚杯。

V Install two pairs of die cast corner seats on both sides of the two cross brace profiles to lock the conveyor line placed above the upper and lower cross braces.

V 在两根横撑型材两侧分别安装两对压铸角座，用于锁紧放置在上下横撑上方的输送线。

Maintenance 维护和保养

The UTS series tray conveying system requires regular maintenance and upkeep to extend the service life of the line. The conveying equipment should be kept clean to avoid direct sunlight or rain or snow, and to prevent contact with substances such as acids, alkalis, oils, organic solvents, etc.

UTS 系列托盘输送系统需按周期进行规定的保养维护工作，以延长线体使用寿命。输送设备应保持清洁避免阳光直射或雨雪浸淋，防止与酸、碱、油类、有机溶剂等物质接触。维护前需关闭对应的能源供给。

W Regularly wipe the leg rest according to the usage environment. When wiping, soft cloth and towel should be used. It is strictly prohibited to use abrasive paper, wire brush, and other friction materials to wipe the surface of aluminum material. Warm water containing lubricants or neutral cleaning agents can be used for cleaning.

W 根据使用环境，定期擦拭腿架。擦洗时需用软布、毛巾，严禁使用砂纸、钢丝刷等摩擦物擦洗铝材表面。可采用含润滑剂或中性清洗剂的温水清洗。

X During packaging and transportation, it is strictly prohibited to loosen the bulk truck to cause scratches.

X 在包装运输过程中严禁松散装车，造成刮擦。

Y Regularly inspect vulnerable parts. Check if the fasteners are loose and tighten them in a timely manner. Check if the profile groove is damaged and replace it in a timely manner.

Y 定期检查易损件。检查紧固件是否松动，及时拧紧。型材槽条是否受损，及时更换。

Disclaimer

免责声明

The customer shall inspect the equipment regularly. If the customer fails to maintain the conveyor as the state above, leading to any malfunction or damage to the conveyor, our company will not be responsible for it, all related costs (including material costs, installation and commissioning fees, and hotel expense) shall be borne by the customer.

客户应定期对设备进行检查。若客户未按要求对输送机进行维护，进而导致输送机发生任何故障或损坏，我司将不承担相关责任，由此产生的相关费用（材料费，安装调试费，差旅费）均由客户承担。

Suzhou LinkedGo Transfer System Co.,Ltd.
苏州领科工业技术有限公司

[Tel: +86-512-6636 1885](tel:+86-512-66361885)

Add: Room 706, Building D, Dongchuang Science and Technology Park, No. 216
Jinfeng Road, Wuzhong District, Suzhou, P.R. China

Zip code:215101

E-mail: Sales@LinkedGo.com.cn

Website: [www. LinkGo.com.cn](http://www.LinkGo.com.cn)

Subject to technical modifications

电话: +86-512-6636 1885

地址: 苏州市吴中区木渎镇金枫路 216 号东创科技园 D 幢 706 室

邮编: 215101

邮箱: Sales@LinkedGo.com.cn

网址: www.LinkGo.com.cn

我司保留技术更改的权利